

Linear Feeder Combinations ER series

11 ER-55B+LFG-700

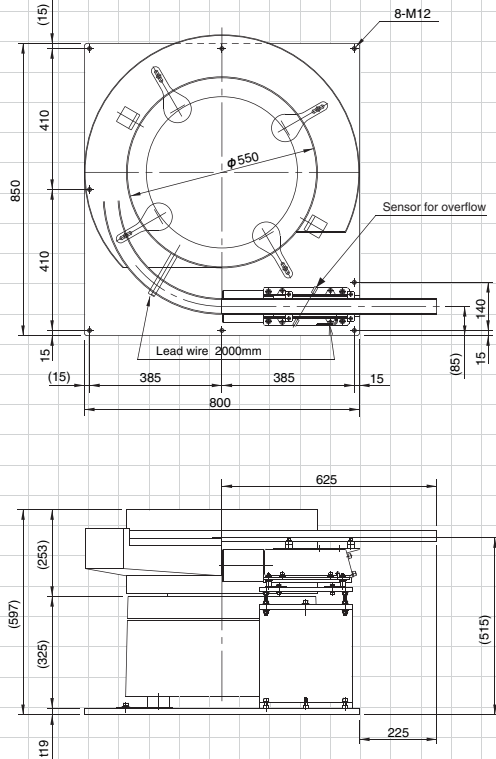

12 ER-65B+LFG-700

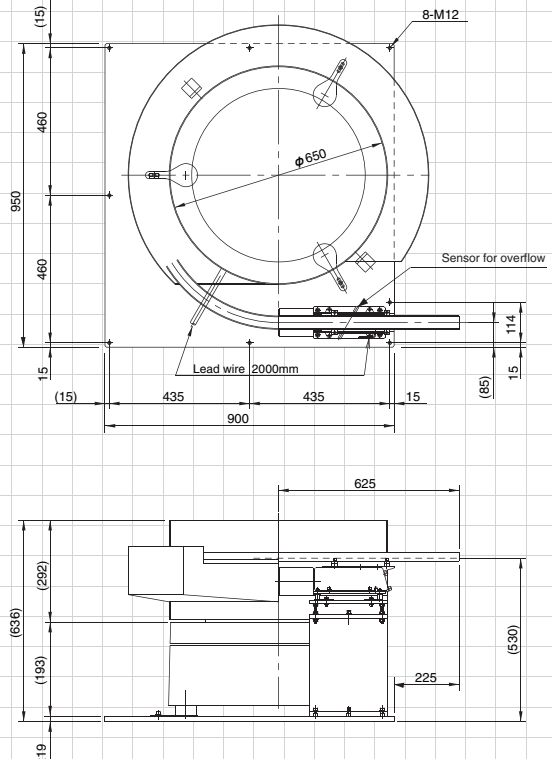

13 ER-75B+LFG-700

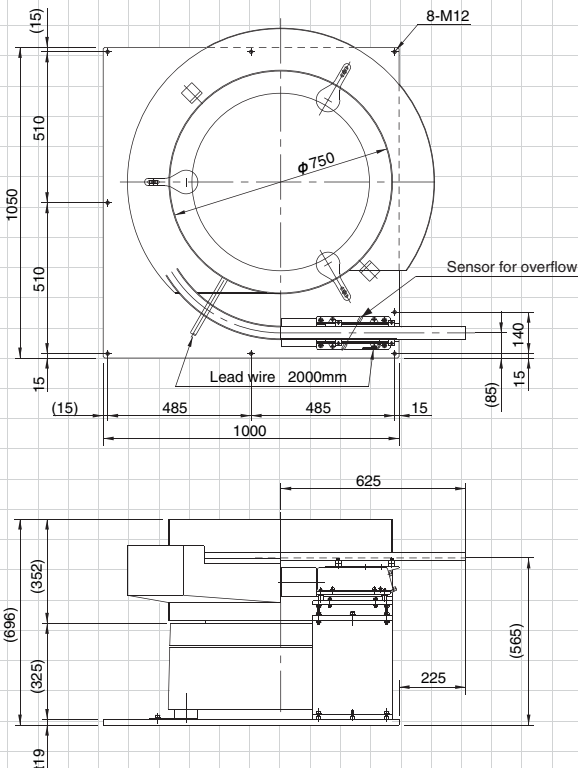

Parts Feeder	Linear Feeder Model					
	Leaf-spring vibro-isolating			Rubber-mount vibro-isolating		
	LFB-300	LFB-400	LFB-550	LFG-400	LFG-550	LFG-700
EA/DMS15	1					
EA/DMS-20	2					
EA/ER/DMS-25		3		4		
EA/ER/DMS-30		5		6		
EA/ER/DMS-38			7		8	
EA/ER/DMS-45			9		10	
ER-55B						11
ER-65B						12
ER-75B						13

Notes:
 All diagrams above show straight wall bowls, however combinations are also possible with track-stepped bowls. (Only bowl diameter and chute exit height vary; all other dimensions are the same for both types of bowl)
 A wide range of combinations is possible, depending on the type of workpiece. We are happy to discuss customers' individual requirements.

(Unit: mm)