

Bowl Dimension EA/ER/DMS series

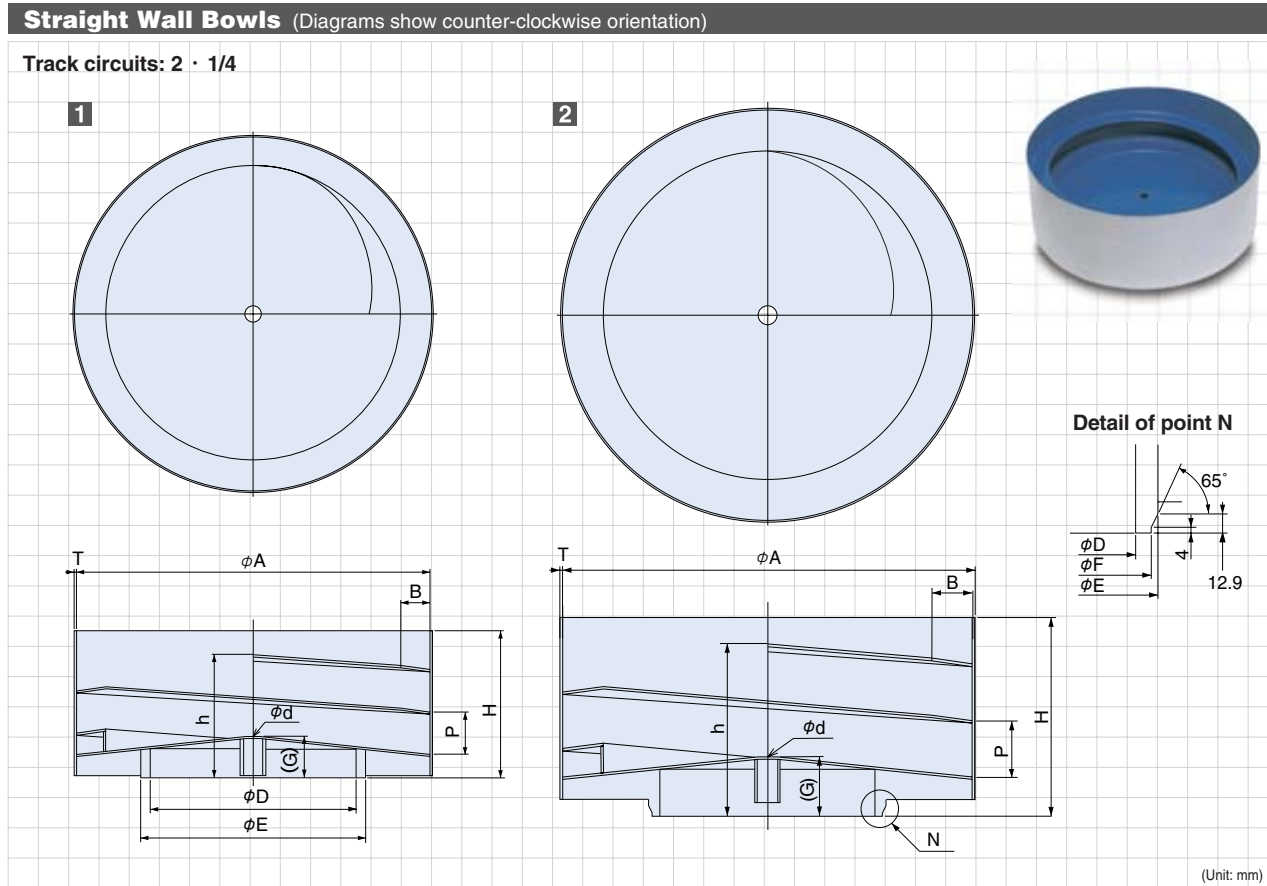

1

Model	ϕA	B	ϕD	ϕE	G	H	P	h	ϕd	T	Approx. Weight (kg)	Capacity (ℓ)
EA/DMS-15	150	12	73.1	89.1	22	70	18	56	8.2	1.5	1.1	0.1
EA/DMS-20	200	18	104	120	25	85	24	69	10.2	1.5	1.8	0.2
EA/ER/DMS-25	250	20	143	159	27	100	30	83	12.2	2	3.2	0.5
EA/ER/DMS-30	300	25	174.7	190.7	35	125	36	101	12.2	2	5.0	0.8
EA/ER/DMS-38	375	35	216	232	43	155	46	129	16.2	2	8.0	1.7
EA/ER/DMS-45	450	40	282.5	298.5	52	190	56	156	16.2	3	15.0	3.0

2

Model	ϕA	B	ϕD	ϕE	ϕF	G	H	P	h	ϕd	T	Approx. Weight (kg)	Capacity (ℓ)
ER-55B	550	55	288.5	318.5	309.2	78	266	76	221	25	3	28	5
ER-65B	650	65	373	406.4	397.2	88	311	90	258	25	3	39	10
ER-75B	750	75	477.8	508	498.7	99	366	108	303	25	3	54	15

Notes 1) Bowls are made of stainless steel. 2) Bowls available with clockwise or counter-clockwise orientation. 3) Capacity varies according to the type of workpiece. *When supplied unprocessed, neither inside nor outside has been surface-treated.

Straight wall Bowl Selection Guide

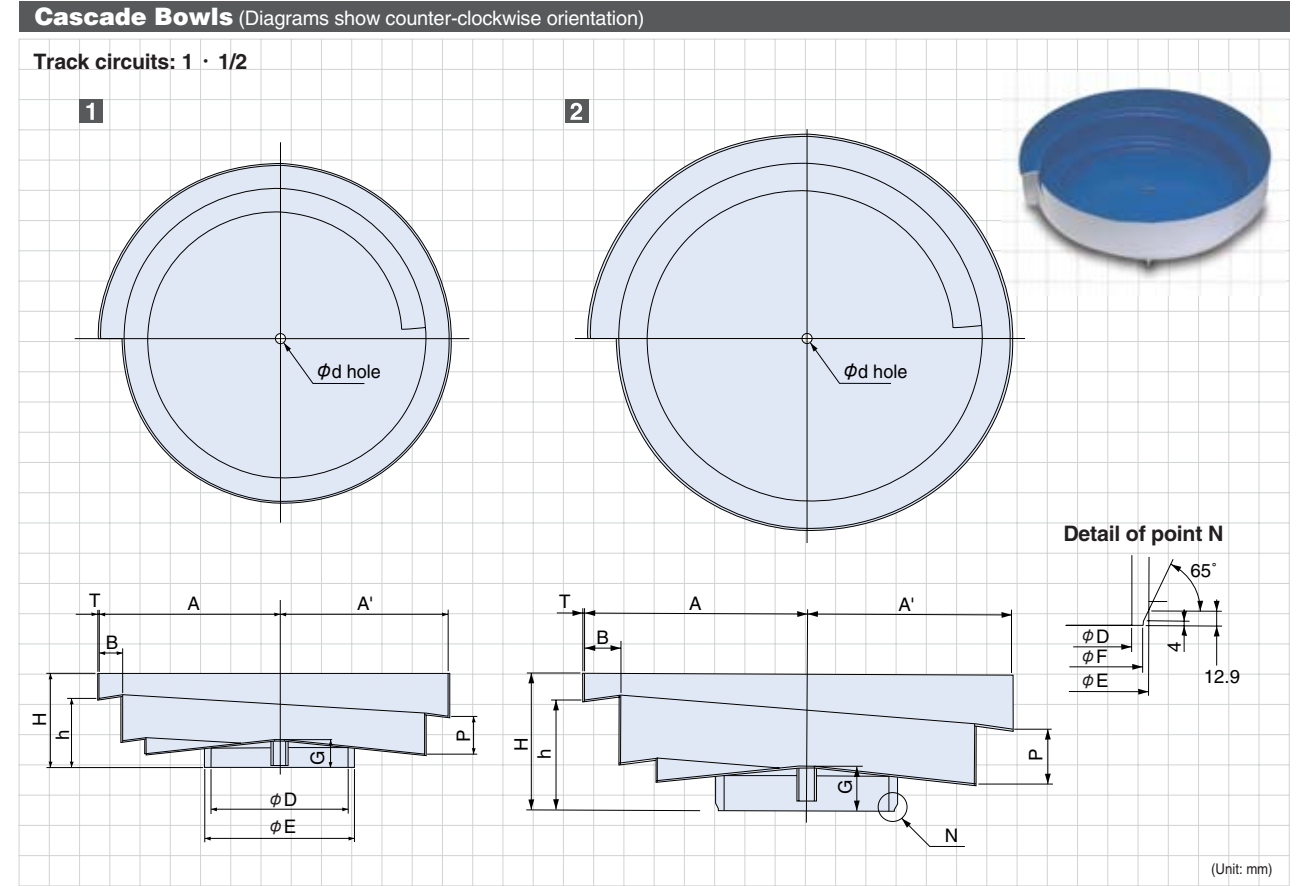
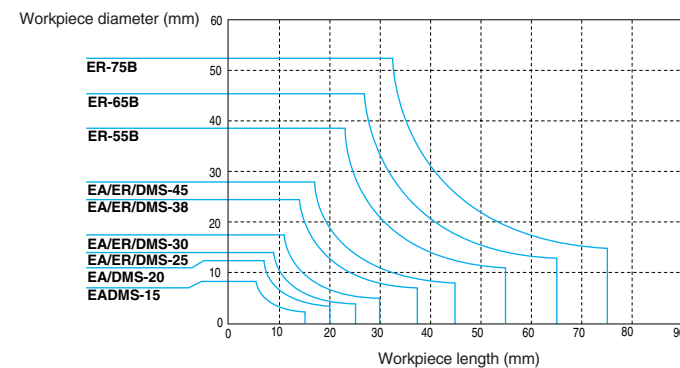

1

Model	Dia. approx.	A	A'	B	H	h	P	ϕd	ϕD	ϕE	G	T	Approx. Weight (kg)	Capacity (ℓ)
EA/DMS-15	215	110	102.5	15	65	50	24	8.2	73.1	89.1	23	2	1.3	0.4
EA/DMS-20	280	145	135	20	80	59	30	10.2	104	120	26	2	2.2	0.8
EA/ER/DMS-25	350	180	167.5	25	95	70	38	12.2	143	159	28	2	3.3	1.6
EA/ER/DMS-30	450	230	215	30	120	88	48	12.2	174.7	190.7	36	2	5.4	3.5
EA/ER/DMS-38	540	280	260	40	150	109	58	16.2	216	232	45	2	8	6
EA/ER/DMS-45	650	335	310	50	185	135	72	16.2	282.5	298.5	54	3	16	10

2

Model	Dia. approx.	A	A'	B	H	h	P	ϕd	ϕD	ϕE	ϕF	G	T	Approx. Weight (kg)	Capacity (ℓ)
ER-55B	750	390	358	64	240	193	96	25	288.5	318.5	309.2	78	3	26	17
ER-65B	850	445	405	80	306	236	120	25	373	406.4	397.2	88	3	37	20
ER-75B	950	495	455	80	346	256	130	25	477.8	508	498.7	99	3	47	25

Notes 1) Bowls are made of stainless steel. 2) Bowls available with clockwise or counter-clockwise orientation. 3) Capacity varies according to the type of workpiece. *When supplied unprocessed, neither inside nor outside has been surface-treated.

Cascade Bowl Selection Guide

