

DM series Drive Units

Can be used with DM series bowls only (see p7)

DM-30C~45C Dimensions

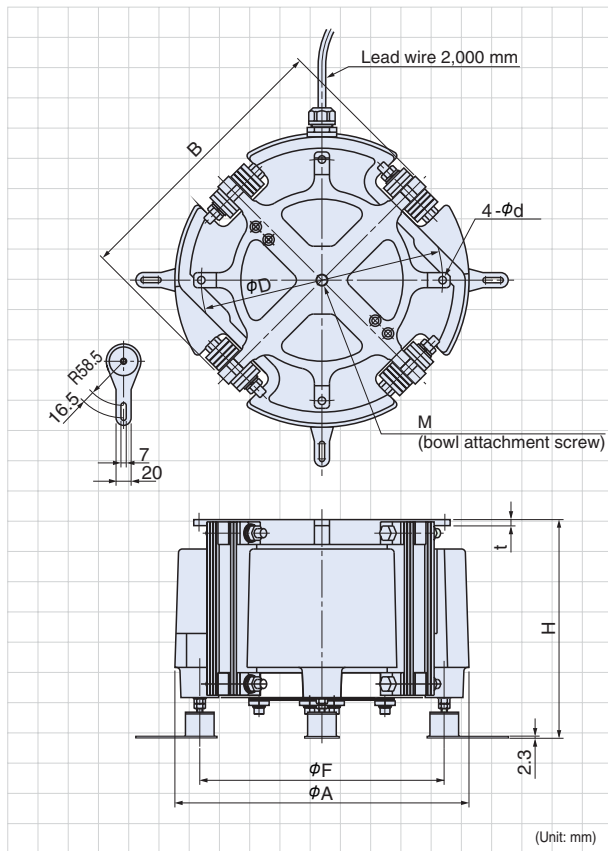

DM-65C Dimensions

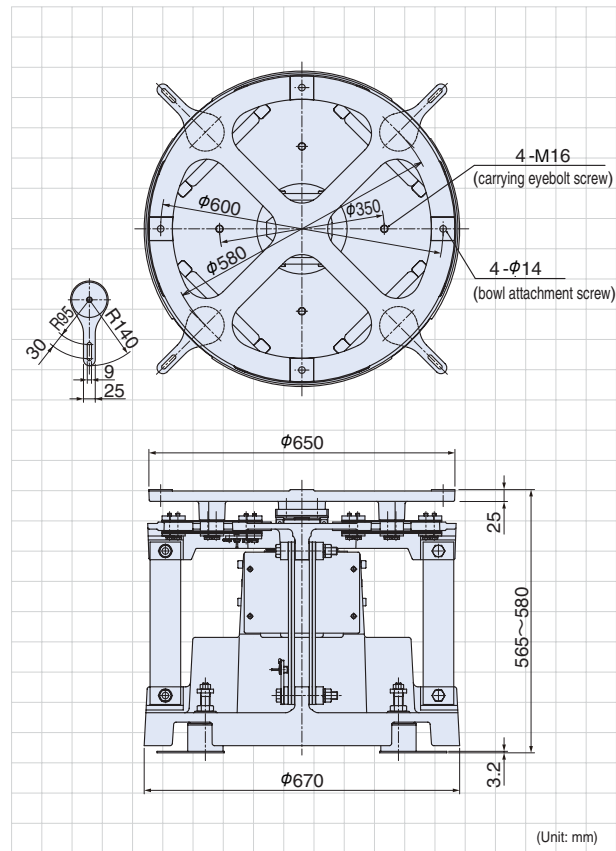

Drive Unit Specifications

Model		DM-30C	DM-38C	DM-45C	DM-65C
Drive unit outer diameter	mm	$\phi 310$	$\phi 390$	$\phi 460$	$\phi 670$
Drive unit height	mm	285~295	290~300	360~370	565~580
Drive unit weight	kg	55	80	140	320
Rated voltage	V	200			
Rated current	A	Horizontal		Vertical	
		2.0	2.0	4.0	4.0
		0.8	0.8	2.0	2.0
Vibration frequency	Hz	70~110		30~40	
Unprocessed bowl diameter (cylindrical)	mm	$\phi 300$	$\phi 375$	$\phi 450$	$\phi 650$
Max. bowl diameter (cylindrical)	mm	$\phi 500$	$\phi 600$	$\phi 700$	$\phi 1000$
Max. amplitude (Unprocessed cylindrical bowl periphery)	mm	Horizontal		Vertical	
		1.8		0.3	
		2.0		4.0	
		0.3		1.0	
Max. loaded weight	kg	9.2	17.0	27.5	70.0
Lead wire		5 x 1.25 mm ² wire			
Applicable controller		C10-4DM			

Dimensions Chart

Model	H	ϕA	B	M	ϕD	ϕd	t	ϕF
DM-30C	285~295	310	290	M12	270	10	8	252
DM-38C	290~300	390	370	M16	320	10	8	324
DM-45C	360~370	460	440	M16	365	12	10	390

Unit: mm