

DMS series Drive Units

Accommodates bowls designed for EA and ER and DMS series (see p13-14)

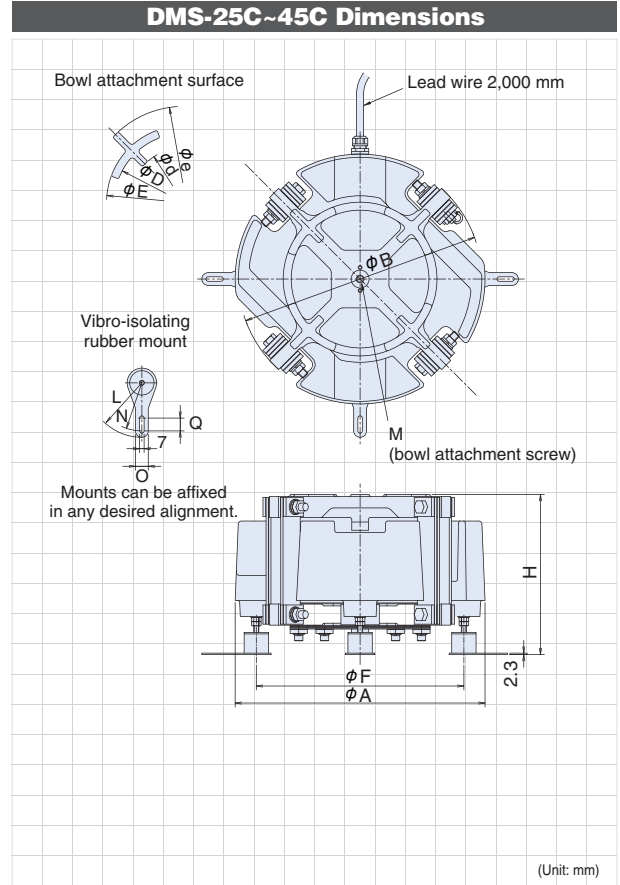
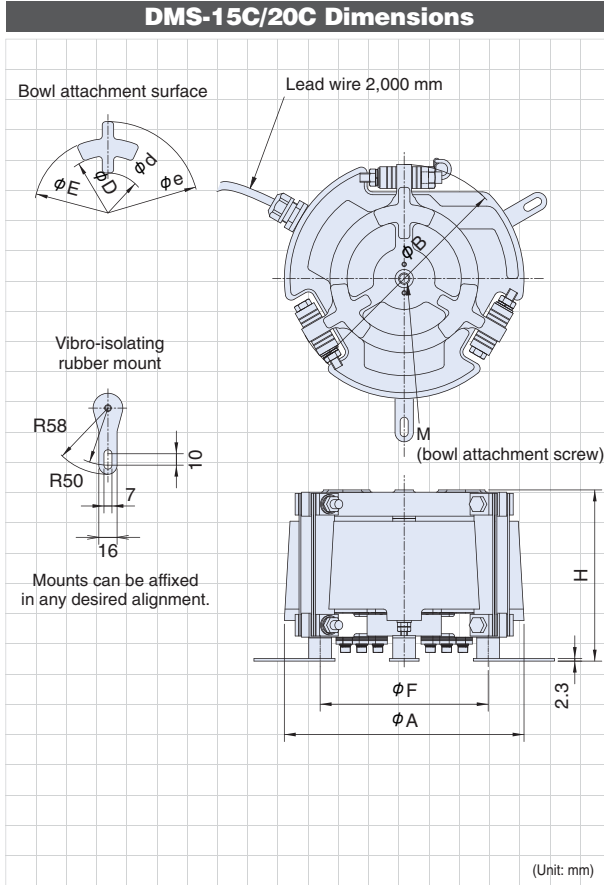

Drive Unit Specifications

Model		DMS-15C	DMS-20C	DMS-25C	DMS-30C	DMS-38C	DMS-45C
Drive unit outer diameter	mm	φ160	φ210	φ260	φ310	φ390	φ460
Drive unit height	mm	130	150	185	220	250	265
Drive unit weight	kg	7	14	25	40	70	110
Rated voltage	V	200					
Rated current	A	Horizontal		Vertical			
		0.15	0.25	0.6	2.0	2.0	2.0
		0.15	0.25	0.3	0.8	0.8	2.0
Vibration frequency	Hz	100~180			70~110		
Unprocessed bowl diameter (cylindrical)	mm	φ150	φ200	φ250	φ300	φ375	φ450
Max. bowl diameter (cylindrical)	mm	φ250	φ320	φ400	φ500	φ600	φ700
Max. amplitude (Unprocessed cylindrical bowl periphery)	mm	Horizontal		Vertical			
		0.6		0.13		1.0	
						0.3	
Max. loaded weight (workpieces + bowl weight)	kg	2.3	4	8	12.5	17	26
Lead wire		5 x 0.5 mm ² wire			5 x 0.75 mm ² wire		
Applicable controller		C10-4DM					

Dimensions Chart

Unit: mm

Model	H	φA	φB	M	φD	φE	φF	φd	φe
DMS-15C	127~130~133	160	150	M8	72	94	130	50	120
DMS-20C	147~150~153	210	200	M10	100	130	170	70	160

Model	H	φA	φB	M	φF	L	N	O	Q	φD	φE	φd	φe
DMS-25C	182~185~188	260	250	M12	216	58	50	16	10	140	160	100	200
DMS-30C	215~220~225	310	300	M12	252	85	75	20	20	172	192	140	240
DMS-38C	245~250~255	390	380	M16	324	85	75	20	20	215	240	170	300
DMS-45C	260~265~270	460	450	M16	390	85	75	20	20	270	300	210	350